



## R5 SERIES

MODELS R5125-2, R5325A-2, R5325B-1

MAX. PRESSURE – 65"H<sub>2</sub>O (60 Hz), 50"H<sub>2</sub>O (50 Hz)

MAX. VACUUM – 60"H<sub>2</sub>O (60 Hz), 47"H<sub>2</sub>O (50 Hz)

MAX. AIR FLOW – 160 CFM (60 Hz), 133 CFM (50 Hz)



### PRODUCT FEATURES

- Rugged construction, low maintenance
- Oilless operation
- UL and CSA approved TEFC motors with permanently sealed ball bearings
- Automatic restart thermal protection on single phase motors
- Aluminum blower housing, impeller and cover
- Can be mounted in any plane
- Inlet and outlet have internal muffling

### RECOMMENDED ACCESSORIES

- Pressure gauge AE133
- Inlet Filter AJ126D (pressure)
- Vacuum gauge AJ497
- Inline filter AJ151E (vacuum)
- Muffler AJ121D
- Relief valve AG258
- Liquid separator RMS200 (vacuum)
- Foam replacement kit K903

### Product Dimensions (in. mm)

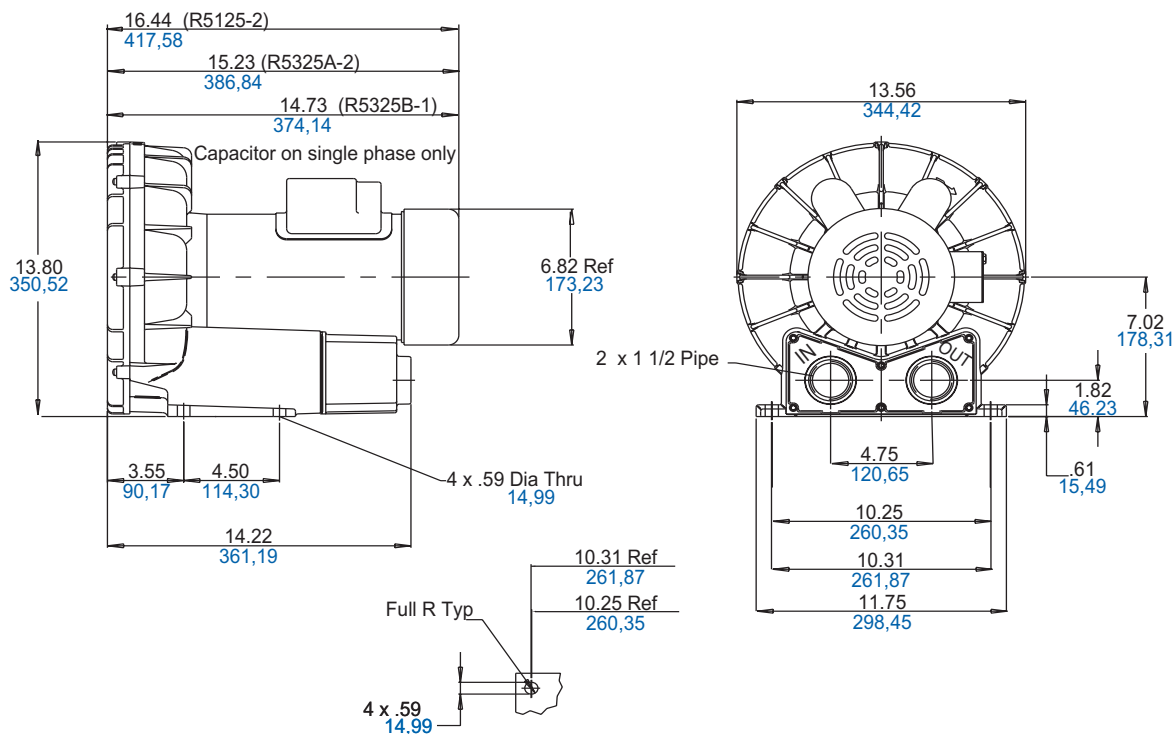



## Product Specifications

MODEL NUMBER		R5125-2	R5325A-2	R5325B-1
Motor Enclosure		TEFC	TEFC	TEFC
HP/kW	60 Hz	2.5/1,9	2.5/1,9	2.5/1,9
	50 Hz	1.5/1,1	1.85/1,38	-
Voltage	60 Hz	115/208-230-1	208-230/460-3	575-3
	50 Hz	110/220-240-1	190-220/380-415-3	-
Amps	60 Hz	23.6/12.9-11.8	6.9-6.9/3.45	2.9
	50 Hz	17.6/8.8-9.5	6.6-6.7/3.3-3.5	-
Starting Amps	60 Hz	76 @ 230V	58 @ 230V	23.4
	50 Hz	Consult Factory	23 @ 380V	-
Insulation Class		B	B	B
Recommended NEMA Starter Size		1/0	0/00	0
Net Weight (lbs/kg)		76/34,5	65/29,5	65/29,5

## Product Performance

